

Take Control.
ION
Technologies

A division of Metropolitan Industries, Inc.



MSE50V

1 YEAR
WARRANTY



Sewage Pump

- Septic tank effluent
- High capacity sump
- Residential sewage
- Light commercial sewage



37 Forestwood Dr., Romeoville, IL 60446
www.ionproducts.net [815] 886-9200

MSE50V

Sewage Pump

System Specifications

Typical Applications	Septic tank effluent High capacity sump Residential sewage Light commercial sewage
Maximum Capacity	Up to 130 GPM
Maximum Head	Up to 22'
Electrical Data	115V, 1 \emptyset , 9.4 FLA, 60Hz
Motor Data	1/2 HP, 1750 RPM
Recommended Minimum Basin Size	18" x 30"
Automatic Operation	V: Vertical switch
Materials of Construction	Cast iron
Impeller	Vortex - Thermoplastic
Power Cord	10'
Discharge Size	2" NPT
Solids Handling	2"

Pump Dimensions

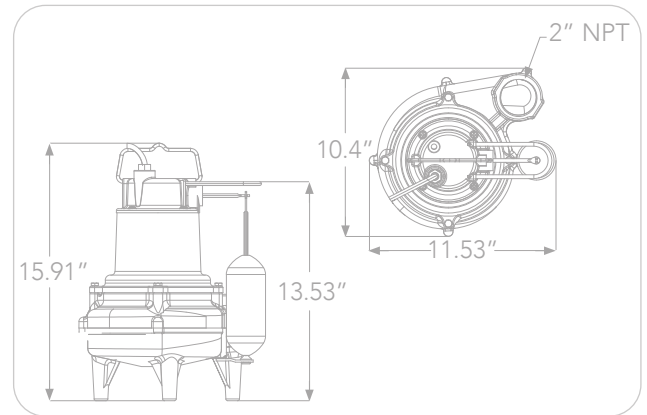

Pump Performance

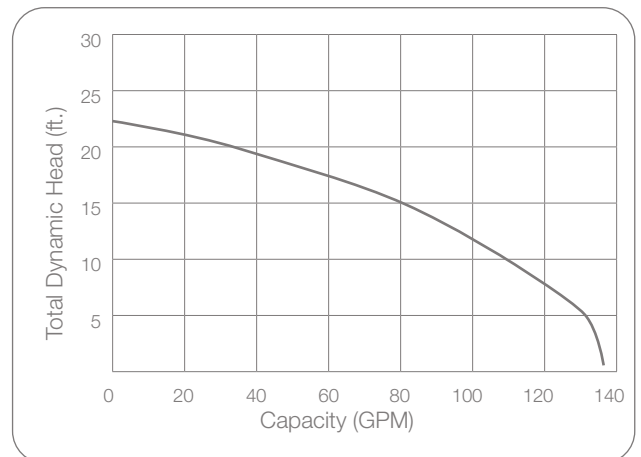

Features

- Heavy duty cast iron construction
- Oil-filled continuous duty PSC motor
- Vortex thermoplastic impeller
- 1 year warranty